

Use When Installing Dresser Reinforcing Sleeves

Dresser® time-proven Style 90 Tap-N-Valve Tees can be used for effective pressure relief when installing Dresser Styles 110, 115 and 220 reinforcing sleeves. As an option, the Style 90 tee is simply welded to the reinforcing sleeve, then tapped through the sleeve body to depressurize the sleeve while repair is being made.

As illustrated in View I, the tee is supplied with a splatter cap to prevent splatter from entering the internal threads of the tapping device. Field contouring of the tee weld inlet is also recommended to reduce the potential for field weld “burn through” and internal weld splatter. Leave weld splatter cap in place to prevent slag from entering threads.

To make the tap, the hollow cutting end of the tapping tool is inserted in the top of the tee and the threads engaged. A hex bar and 14” ratchet wrench are then used to rotate the tapping tool in a clockwise direction until the cutting edge touches the sleeve. As tip of tool penetrates through the sleeve wall, the required wrench pull or torque will decrease. Once the tap is complete, the tool is seated and the slug of the sleeve is retained in the tool (View II). The wrench is then rotated in a counter-clockwise direction until the tool is flush with the top of the tee body.

NOTE: The tapping tool must be removed from inside the tee body while welding the sleeve. Place tool in plastic bag while welding - The tee must be cool before reinserting the tapping tool. The tee cap is then tightened onto the tee body and the tap is complete. Pressure relief is then realized through the tee branch during the welding procedure. (View III).

NOTE: Field contouring of the tee weld inlet to the pipe radius is suggested to improve weld prep and helps to reduce weld burn through and internal weld splatter.

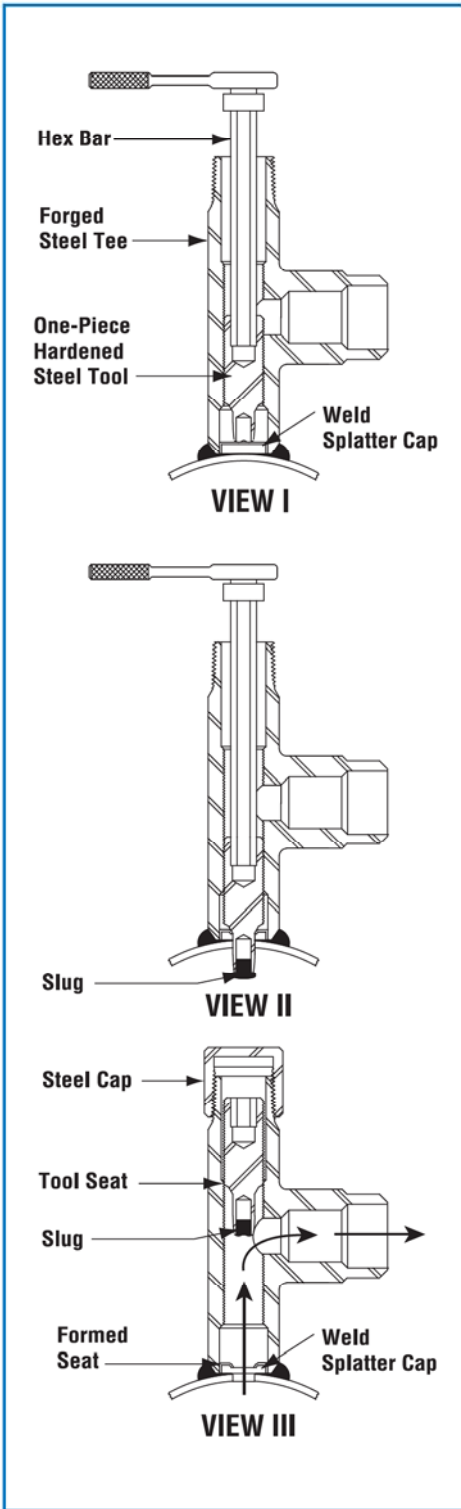
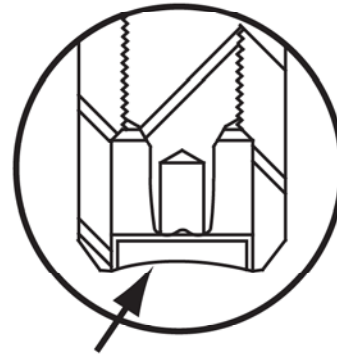

⚠ WARNING

On Weld Inlet Tees, remove tapping tool and all compression end components before welding. Failure to do so could damage the tapping tool and destroy the gasket, resulting in escaping gas that could ignite and cause property damage, serious injury or death.