



Job Name: _____
 Job Location: _____
 Contractor: _____
 Engineer: _____
 Approval: _____

Stainless Steel Junior Duo Strainer

Design Features:

- Stainless Steel Construction
- Furnished with Basket Strainer
- Imported

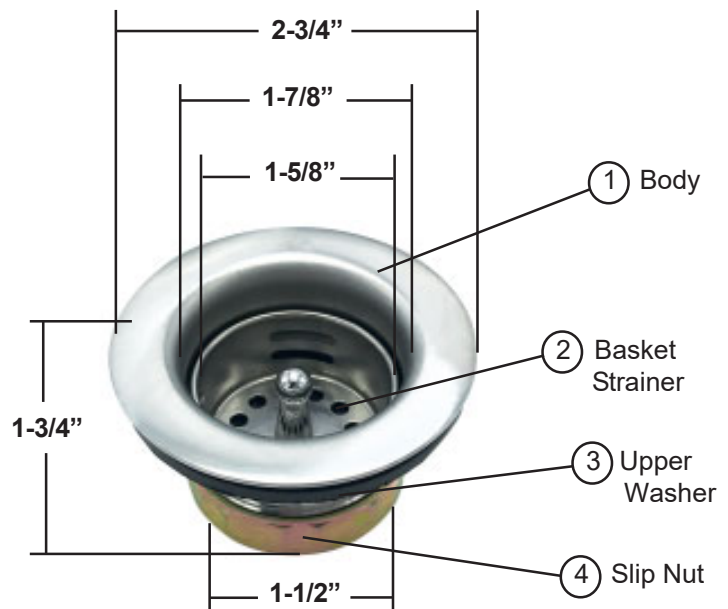

Material Specifications		
No.	Part	Material
1	Body	Stainless Steel
2	Basket Strainer Strainer Seat	Stainless Steel Rubber
3	Upper Washer	Rubber
4	Slip Nut	Zinc Die Cast
	Lock Nut	Zinc Die Cast
	Lower Washer	Paper
	Slip Nut Washer	Nylon

W-R#	Description	Weight	Min	Box
0505002	Jr. Duo	.333 lbs.	1	12
0506002	Basket Strainer Only	.050 lbs.	1	12