



Job Name: _____

Job Location: _____

Contractor: _____

Engineer: _____

Approval: _____

Deep Basket Junior Duo Strainer

Design Features:

- Brass Construction
- Chrome-Plated
- Furnished with 2" Basket Strainer
- Imported

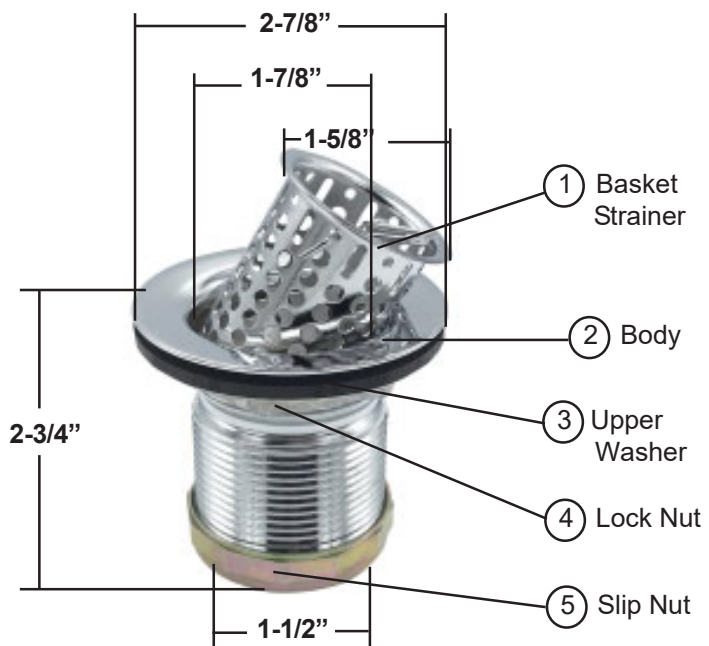

Material Specifications		
No.	Part	Material
1	Basket Strainer	CP Steel
2	Body	CP Brass
3	Upper Washer	Rubber
4	Lock Nut	Zinc Die Cast
5	Slip Nut	Zinc Die Cast
	Lower Washer	Paper
	Slip Nut Washer	Rubber

W-R#	Description	Weight	Min	Box
0505004	Deep Jr. Duo	.473 lbs.	1	12
0505003	Basket Strainer Only	.061 lbs.	1	12