



Job Name: _____

Job Location: _____

Contractor: _____

Engineer: _____

Approval: _____

Chrome-Plated Shower Stall Strainer

Design Features:

- Grid
- Stainless Steel Construction
- 14 Variable Length Slots
- 2/10" Wide Slots
- 2/10" Between Slots
- Base Available in Chrome-Plated Die-Cast or Rough Brass Construction
- Imported

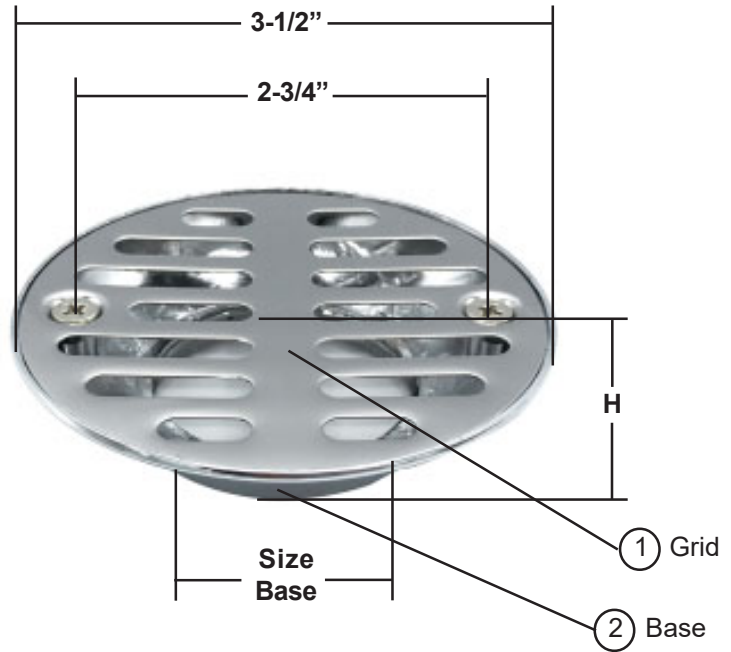

Material Specifications		
No.	Part	Material
1	Grid	Stainless Steel
2	Base	CP Die Cast or Rough Brass

W-R#	Size Base	H	Base Material	Weight	Min	Box
0522002	1-1/2"	7/8"	CP Die-Cast	.169 lbs.	1	12
0522004	1-1/2"	1"	Rough Brass	.427 lbs.	1	12
0522006	2"	7/8"	CP Die-Cast	.157 lbs.	1	12
0522008	2"	1"	Rough Brass	.470 lbs.	1	12
0530002	<i>Grid Only</i>		3-1/2" OD	.0285 lbs.	12	12