



Job Name: _____

Job Location: _____

Contractor: _____

Engineer: _____

Approval: _____

Twin Mix Connection

Design Features:

- 3/4" Male Hose x 3/4" Female Hose
- Imported

Use: For installation of portable washing machines.

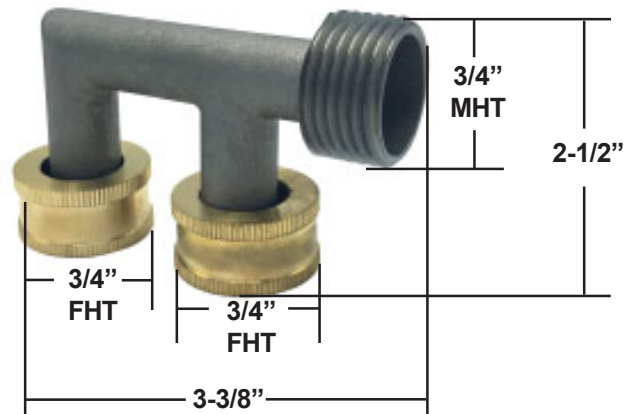

Material Specifications	
Part	Material
Body	Die Cast
Swivel Connection	Brass
Washers	Rubber

W-R#	Description	Weight	Min	Box
0818002	Connection	.265 lbs.	1	12