



Job Name: _____

Job Location: _____

Contractor: _____

Engineer: _____

Approval: _____

PVC Slip Elbow

Design Features:

- PVC Construction
- Individually Bagged
- Imported

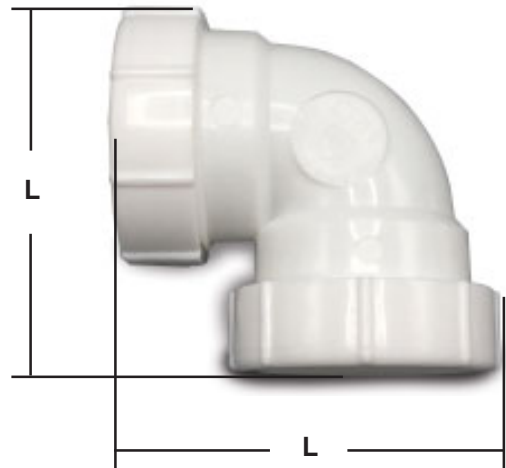

Material Specifications	
Part	Material
Body	Virgin Polyvinyl Chloride
Slipnuts	Virgin Polyvinyl Chloride
Washers	Nylon



ASTM F-409: Standard specification for thermoplastic accessible and replaceable plastic tube and tubular fittings

W-R#	Size	Angle	L	Weight	Min	Box
1109002	1-1/2"	90°	3"	.0875 lbs.	1	25
1109004	1-1/2"	45°	4"	.0925 lbs.	1	25