



Job Name: _____

Job Location: _____

Contractor: _____

Engineer: _____

Approval: _____

Nylon Toilet Seat Bolt, Nut, and Washer

Design Features:

- Nylon Construction
- Includes 5/16" Bolt, Nut, and Washer
- Bagged Pair per Bag
- Imported

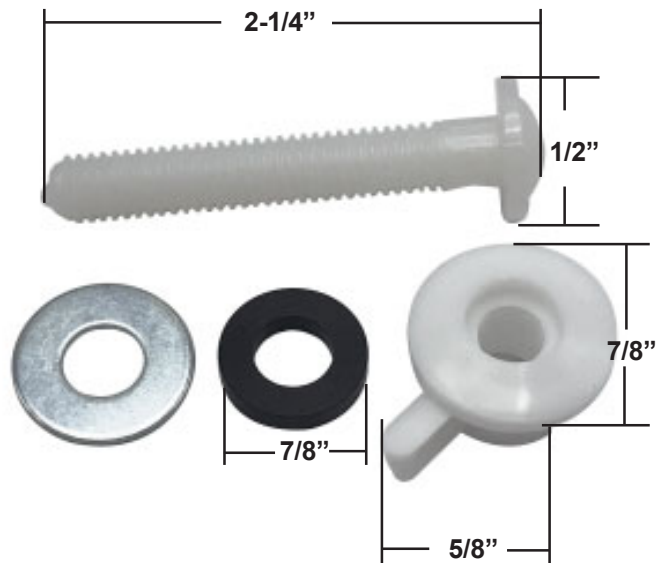

W-R#	Size	Weight	Min	Box
1365002	5/16" x 2-1/4"	.060 lbs.	1 pr.	24 pr.