



Job Name: _____

Job Location: _____

Contractor: _____

Engineer: _____

Approval: _____

Spring Coupler for B&G

Design Features:

- Shaft Diameters 1/2" x 1/2"

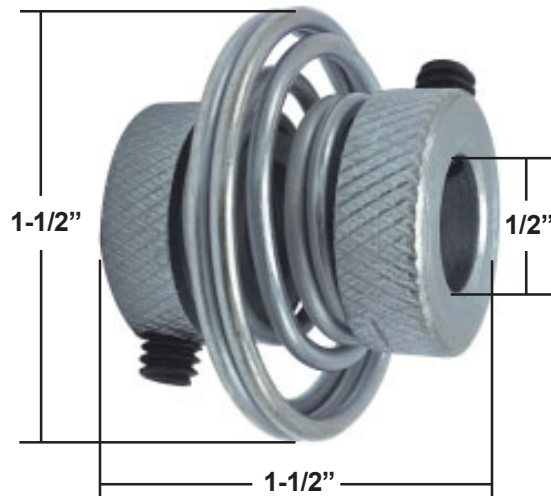

W-R#	Description	Weight	Min	Box
1751030	Fits B&G 100 Booster Pumps	.090 lbs.	1	12