



Job Name: _____

Job Location: _____

Contractor: _____

Engineer: _____

Approval: _____

“C” Clamp

Design Features:

- Steel Construction
- Black Finish
- Domestic

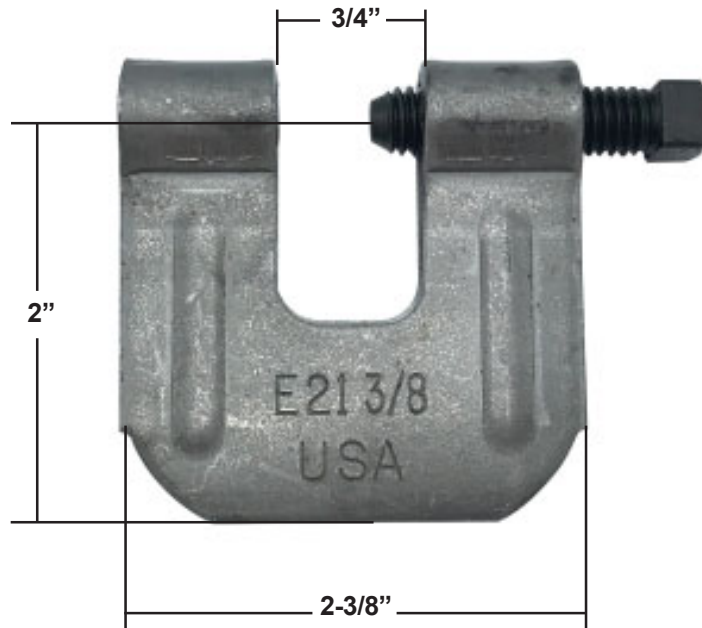

Material Specifications	
Part	Material
Clamp Body	Steel

W-R#	Size	Finish	Max Rec Load	Weight	Min	Box
------	------	--------	--------------	--------	-----	-----

2432002	3/8"	Black	400 lbs.	.375 lbs.	1	25
---------	------	-------	----------	-----------	---	----