



Job Name: \_\_\_\_\_  
 Job Location: \_\_\_\_\_  
 Contractor: \_\_\_\_\_  
 Engineer: \_\_\_\_\_  
 Approval: \_\_\_\_\_

# 16 Gauge 16-Hole FHA Straps

## Design Features:

- 16 Gauge
- Domestic



Operating Specifications			
Allowable Tension Load			
DF/SP		SPF/HF	
(133)*	(160)*	(133)*	(160)*
1500	1800	1300	1550

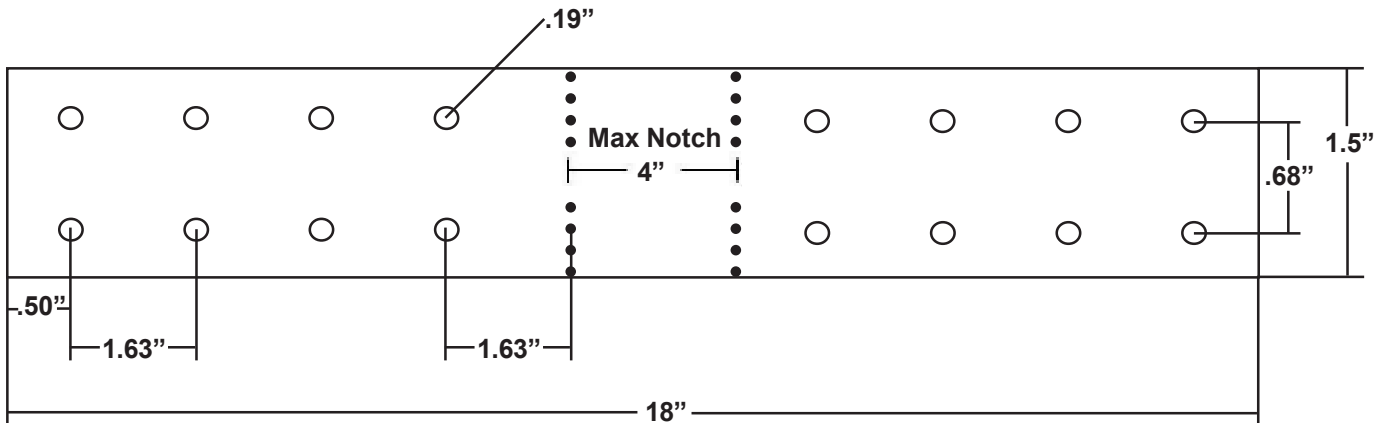

W-R#	Length	Weight	Min	Box
------	--------	--------	-----	-----

2432750	18"	.4565 lbs.	1	50
---------	-----	------------	---	----

\* Seismic and wind loadings are increased 33% (133) or 60% (160) for load duration.