



Job Name: _____

Job Location: _____

Contractor: _____

Engineer: _____

Approval: _____

Con-Stab® Saddle Tees

Design Features:

- Continental's Patented "ID Seal"
- For Underground PE Pipe (ASTM D 2513) Only
- 316 Stainless Steel Bolts, Washers & Inserts
- Made in the USA

Operating Specifications:

Temperature: -20° to 140° F

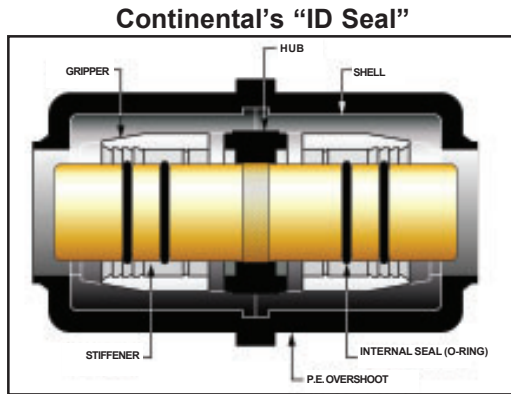
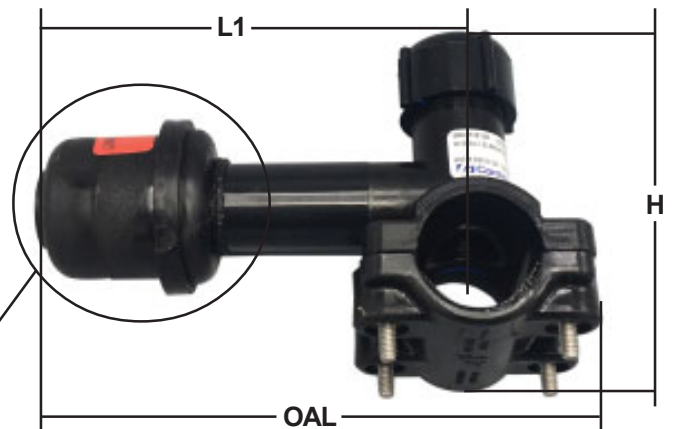

Pressure: 125 psi



You must use a Continental Chamfer Tool on a Continental Fitting

Always Match Pipe Size & SDR



 NFPA 58, LP-Gas Code
 NFPA 54, National Fuel Gas Code
 IAPMO - Uniform Plumbing Code
 ICC - International Plumbing Code
 Approved by the Commonwealth of Massachusetts
 D.O.T., Title 49 of the Code of Federal Regulations, Part 192.283 (b)
 ASME B31.8-1995 "Gas Transmission and Distribution Piping Systems"
 ASTM D 2513 "Standard Specifications for Thermoplastic Gas Pressure Pipe, Tubing and Fittings"

| W-R# | Main | Outlet | SDR | H | L1 | OAL | W | Weight | Required Chamfer Tool |
|---------|--------|--------|--------|----------|----------|----------|---------|-----------|-----------------------|
| 2893090 | 1-1/4" | 3/4" | SDR-11 | 4-13/16" | 6-1/2" | 8-1/16" | 4" | 1.20 lbs. | 2888014 |
| 2893092 | 1-1/4" | 1" | SDR-11 | 4-13/16" | 6-1/2" | 8-1/16" | 4" | 1.29 lbs. | 2888016 |
| 2896002 | 1-1/2" | 3/4" | SDR-11 | 5-7/8" | 6-3/8" | 8-1/2" | 4" | 1.67 lbs. | 2888014 |
| 2896006 | 1-1/2" | 1" | SDR-11 | 5-7/8" | 6-3/8" | 8-1/2" | 4" | 1.75 lbs. | 2888016 |
| 2894002 | 2" | 3/4" | SDR-11 | 5-5/8" | 6-3/16" | 8-1/4" | 4" | 1.44 lbs. | 2888014 |
| 2894004 | 2" | 1" | SDR-11 | 5-5/8" | 6-3/16" | 8-1/4" | 4" | 1.53 lbs. | 2888016 |
| 2894006 | 2" | 1-1/4" | SDR-11 | 8-1/2" | 9-5/8" | 11-7/8" | 6" | 1.53 lbs. | 2888007 |
| 2894502 | 3" | 3/4" | SDR-11 | 7-3/16" | 6-11/16" | 9-1/4" | 3-7/16" | 1.52 lbs. | 2888014 |
| 2894504 | 3" | 1" | SDR-11 | 7-3/16" | 6-11/16" | 9-1/4" | 3-7/16" | 1.61 lbs. | 2888016 |
| 2894506 | 3" | 1-1/4" | SDR-11 | 9-5/8" | 9-9/16" | 12-7/16" | 5-3/4" | 1.20 lbs. | 2888007 |
| 2894508 | 3" | 2" | SDR-11 | 9-5/8" | 9-9/16" | 12-7/16" | 5-3/4" | 1.29 lbs. | 2888010 |