



Job Name: \_\_\_\_\_

Job Location: \_\_\_\_\_

Contractor: \_\_\_\_\_

Engineer: \_\_\_\_\_

Approval: \_\_\_\_\_

# Replacement Spindle Assembly for Pre-Rinse

## Design Features:

- Lead Free\* Brass Construction
- Furnished with Index Buttons
- Imported

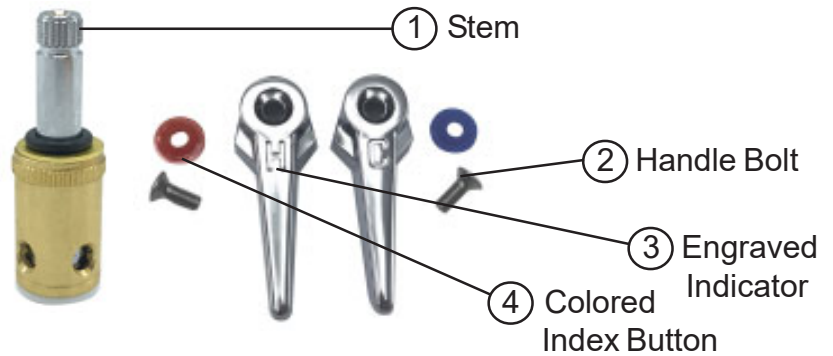

\*The wetted surface of this product contacted by consumable water contains less than one quarter of a percent (.25%) of lead by weight.

Material Specifications		
No.	Part	Material
1	Stem	CP Brass
2	Handle Bolt	Steel
3	Cold Indicator Hot Indicator	Engraved "C" Engraved "H"
4	Cold Index Button Hot Index Button	Blue Plastic Red Plastic
5	Handle Body	CP Die Cast
6	Bonnet	CP Brass
7	Barrel	Brass
Seals and Washers		Rubber

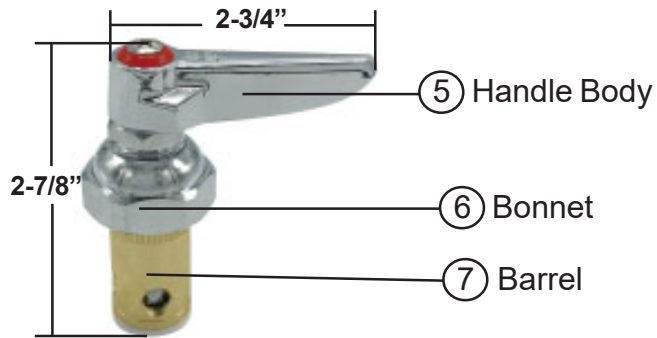

Meets AB1953/NSF61G Standard

W-R#	Description	Comparable OEM#	Weight
<b>CJ500HLF</b>	Hot Spindle Assembly	2714-40	.531 lbs.
<b>CJ500CLF</b>	Cold Spindle Assembly	2713-40	.531 lbs.
<b>CJ401HLF</b>	Hot Stem and Barrel Only	788-20/811-25	.295 lbs.
<b>CJ401CLF</b>	Cold Stem and Barrel Only	789-20/812-25	.295 lbs.
<b>CJ302</b>	Pair of Hot and Cold Handles Only	1636-45 & 1637-45	.270 lbs.