

Style 90™ Compression Fittings for Water

SEAL-ONLY Boltless Couplings & Fittings for Water,
Wastewater and Industrial Steel Piping Systems

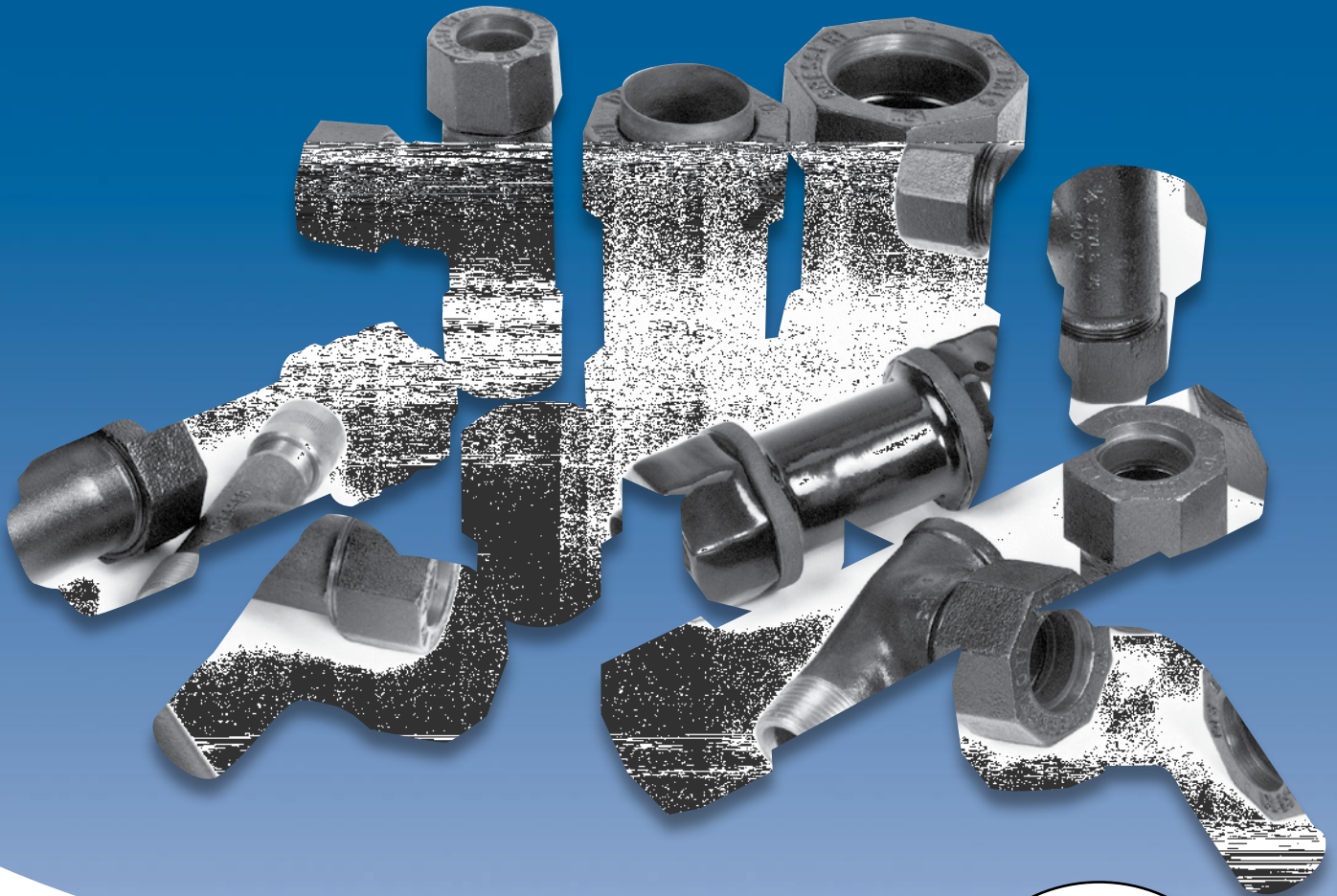

For Joining Steel Pipe to Steel Pipe (Seal Only)

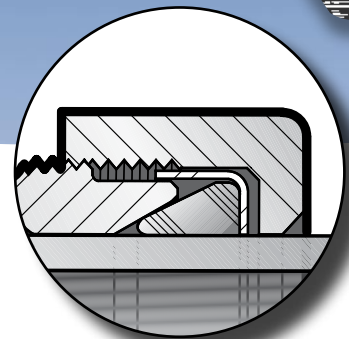

Style 90 SEAL-ONLY Compression Fittings for Water Service Applications*

For Steel to Steel Pipe Connections...

Over the years, millions of Dresser® Style 90 couplings and fittings have been installed on water service lines where they have helped to speed installation and cut costs.

Style 90 couplings and fittings consist of a cast iron or forged steel body; two resilient, specially compounded gaskets; two steel, self-centering protective gasket retainer cups; and two heavy end nuts. All fittings are shipped assembled, ready-to-use and install in just a few minutes. 150 PSIG Standard.

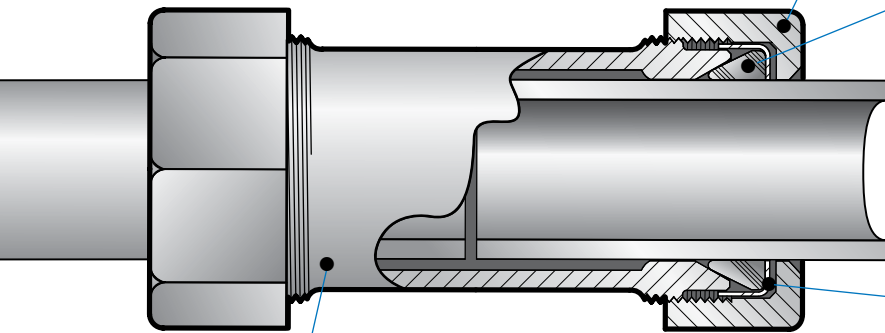

Body

- Made of rugged iron or cast-steel with a machined, wedge-shaped flare that provides a perfect gasket seat and uniform pack at all points.
- Thickness always at least equal to that of pipe (on couplings, ells & tees).
- Longitudinal pipe movement up to 1/16" per gasket may be safely absorbed.

End Nut

- High grade iron, perfectly formed and rigidly inspected.
- Long threading affords reserve "take-up" on gasket when needed and prevents stripping. Robust thread design resists stripping. (Test torques of 600 ft. lbs. reveal no stripping.)

Gasket

- An ample, wedge-shaped section gives reserve packing power and high gasket pressure.
- Scientifically compounded rubber is made to last the life of the pipe.
- Interchangeable with most of the corresponding sizes of gaskets used in Style 38 bolted couplings.

Gasket Retainer Cup

- Cup-shaped design protects gasket and prevents friction between the gasket and end nut.
- Eliminates gasket interference in end nut threads, providing an accurate sense of tightness.
- Closely confines the gasket, permitting more clearance between the end nut and pipe, and greater pipe deflection.

Style 90 Product and Size Specifications For Joining Steel Pipe (Seal Only)

Nominal Size (IPS) (In.)	Outside Diameter (O.D.) (In.)	E-Coat Part Number	Overall Dimensions					Dimension Drawing
			A	B	C	D	E	
CAST COUPLING WITH 5" MIDDLE RING - SEAL ONLY								
1/2	0.840	0090-0014-082	2	5 7/8	5	--	--	
3/4	1.050	0090-0001-082	2 7/32	5 7/8	5	--	--	
1	1.315	0090-0002-082	2 9/16	5 7/8	5	--	--	
1 1/4	1.660	0090-0003-082	3	5 7/8	5	--	--	
1 1/2	1.900	0090-0004-082	3 3/8	5 5/16	5	--	--	
2	2.375	0090-0005-082	4	6 1/8	5	--	--	
CAST-STEEL COUPLING WITH 5" MIDDLE RING - SEAL ONLY								
3/4	1.050	0090-2101-082	2 7/32	5 7/8	5	--	--	
1	1.315	0090-2102-082	2 9/16	5 7/8	5	--	--	
1 1/4	1.660	0090-2103-082	3	5 7/8	5	--	--	
1 1/2	1.900	0090-2104-082	3 3/8	5 5/16	5	--	--	
2	2.375	0090-2105-082	4	6 1/8	5	--	--	
CAST-STEEL COUPLING WITH 10" MIDDLE RING - SEAL ONLY								
3/4	1.050	0090-0090-082	2 7/32	10 7/8	10	--	--	
1	1.315	0090-0091-082	2 9/16	10 7/8	10	--	--	
1 1/4	1.660	0090-0092-082	3	10 7/8	10	--	--	
1 1/2	1.900	0090-0093-082	3 3/8	10 7/8	10	--	--	
2	2.375	0090-0094-082	4	11 1/8	10	--	--	

*Pressure Ratings up to 150 PSI as standard. Other pressure ratings available up to 1200 PSI, please consult factory.

Style 90 Product and Size Specifications For Joining Steel Pipe (Seal Only)

Nominal Size (IPS) (In.)	Outside Diameter (O.D.) (In.)	E-Coat Part Number	Overall Dimensions					Dimension Drawing	
			A	B	C	D	E		
REDUCING COUPLING - SEAL ONLY									
$\frac{3}{4} \times \frac{1}{2}$	1.050 x .840	0090-0590-082	$\frac{27}{32}$	$\frac{57}{8}$	5	2	--		
$1 \times \frac{3}{4}$	1.315 x 1.050	0090-0580-082	$\frac{29}{16}$	$\frac{57}{8}$	5	$\frac{27}{32}$	--		
$1\frac{1}{4} \times \frac{3}{4}$	1.660 x 1.050	0090-0581-082	3	$\frac{57}{8}$	5	$\frac{27}{32}$	--		
$1\frac{1}{4} \times 1$	1.660 x 1.315	0090-0582-082	3	$\frac{57}{8}$	5	$\frac{29}{16}$	--		
$1\frac{1}{2} \times \frac{3}{4}$	1.900 x 1.050	0090-0583-082	$\frac{33}{8}$	$\frac{57}{8}$	5	$\frac{27}{32}$	--		
$1\frac{1}{2} \times 1$	1.900 x 1.315	0090-0584-082	$\frac{33}{8}$	$\frac{57}{8}$	5	$\frac{29}{16}$	--		
$1\frac{1}{2} \times 1\frac{1}{4}$	1.900 x 1.660	0090-0585-082	$\frac{33}{8}$	$\frac{57}{8}$	5	3	--		
$2 \times \frac{3}{4}$	2.375 x 1.050	0090-0586-082	4	6	5	$\frac{27}{32}$	--		
2×1	2.375 x 1.315	0090-0587-082	4	6	5	$\frac{29}{16}$	--		
$2 \times 1\frac{1}{4}$	2.375 x 1.660	0090-0588-082	4	6	5	3	--		
$2 \times 1\frac{1}{2}$	2.375 x 1.900	0090-0591-082	4	6	5	$\frac{33}{8}$	--		
REGULAR TEE - SEAL ONLY									
$\frac{3}{4} \times \frac{3}{4} \times \frac{3}{4}$	1.050 x 1.050 x 1.050	0090-0710-082	$\frac{27}{32}$	$6\frac{1}{4}$	$5\frac{3}{8}$	$\frac{11}{16}$	$\frac{31}{8}$		
$1 \times 1 \times 1$	1.315 x 1.315 x 1.315	0090-0711-082	$\frac{29}{16}$	$\frac{57}{8}$	5	$\frac{11}{16}$	$\frac{37}{16}$		
$1\frac{1}{4} \times 1\frac{1}{4} \times 1\frac{1}{4}$	1.660 x 1.660 x 1.660	0090-0712-082	3	$6\frac{13}{32}$	$5\frac{17}{32}$	$\frac{15}{16}$	$\frac{31}{4}$		
$2 \times 2 \times 2$	2.375 x 2.375 x 2.375	0090-0716-082	4	$8\frac{1}{8}$	$7\frac{1}{4}$	$1\frac{3}{8}$	$4\frac{3}{16}$		
90° ELL - SEAL ONLY									
$\frac{3}{4}$	1.050	0090-0241-082	$\frac{27}{32}$	$\frac{31}{8}$	2	$\frac{11}{16}$	--		
1	1.315	0090-0242-082	$\frac{29}{16}$	$\frac{33}{16}$	2	$\frac{3}{4}$	--		
$1\frac{1}{4}$	1.660	0090-0243-082	3	$\frac{31}{4}$	$1\frac{7}{8}$	$\frac{15}{16}$	--		
$1\frac{1}{2}$	1.900	0090-0244-082	$\frac{33}{8}$	$\frac{319}{32}$	2	$\frac{11}{8}$	--		
2	2.375	0090-0245-082	4	$4\frac{3}{16}$	$2\frac{1}{4}$	$1\frac{3}{8}$	--		
PLAIN END 90° STREET ELL - SEAL ONLY									
$\frac{3}{4}$	1.050	0090-0270-082	$\frac{27}{32}$	$\frac{39}{16}$	3	2	$\frac{9}{16}$		
1	1.315	0090-0271-082	$\frac{29}{16}$	$\frac{33}{8}$	$2\frac{13}{16}$	$\frac{15}{8}$	$\frac{3}{4}$		
$1\frac{1}{4}$	1.660	0090-0272-082	3	4	$\frac{33}{16}$	$\frac{17}{8}$	$\frac{7}{8}$		
$1\frac{1}{2}$	1.900	0090-0273-082	$\frac{33}{8}$	$4\frac{5}{16}$	$\frac{315}{32}$	2	1		
2	2.375	0090-0274-082	4	$5\frac{1}{8}$	$4\frac{1}{16}$	$2\frac{1}{4}$	$1\frac{1}{4}$		
THREADED END 90° ELL - SEAL ONLY									
1	1.315	0090-0331-082	$\frac{29}{16}$	$2\frac{5}{16}$	$2\frac{13}{16}$	$\frac{15}{8}$	$\frac{3}{4}$		
$1\frac{1}{4}$	1.660	0090-0332-082	3	$2\frac{7}{8}$	$\frac{33}{16}$	$\frac{17}{8}$	$\frac{7}{8}$		
2	2.375	0090-0334-082	4	$3\frac{1}{2}$	$4\frac{1}{16}$	$2\frac{1}{4}$	$1\frac{1}{4}$		

Style 90 Product and Size Specifications For Joining Steel Pipe (Seal Only)

Nominal Size (IPS) (In.)	Outside Diameter (O.D.) (In.)	E-Coat Part Number	Overall Dimensions					Dimension Drawing
			A	B	C	D	E	
STREET TEE - SEAL ONLY								
3/4	1.050	0090-0390-082	2 ¹ / ₁₆	1 ³ / ₄	2 ¹ / ₄	3	2 ³ / ₄	
1	1.315	0090-0391-082	2 ⁹ / ₁₆	1 ⁵ / ₈	2 ³ / ₄	2 ¹³ / ₁₆	1 ⁵ / ₈	
1 ¹ / ₄	1.660	0090-0392-082	3	1 ¹³ / ₁₆	2 ⁷ / ₈	3 ³ / ₁₆	1 ⁷ / ₈	
1 ¹ / ₂	1.900	0090-0393-082	3 ³ / ₈	2	3 ¹ / ₁₆	3 ¹⁵ / ₃₂	2	
2	2.375	0090-0394-082	4	2 ⁵ / ₁₆	3 ⁵ / ₁₆	4 ¹ / ₁₆	2 ¹ / ₄	
REDUCING STREET TEE - SEAL ONLY								
1 ¹ / ₄ x 1 ¹ / ₄ x 1	1.660 x 1.660 x 1.315	0090-0451-082	2 ⁹ / ₁₆	1 ³ / ₄	2 ³ / ₄	2 ¹⁵ / ₁₆	1 ⁵ / ₈	
1 ¹ / ₄ x 1 x 1 ¹ / ₄	1.660 x 1.315 x 1.660	0090-0452-082	3	1 ¹³ / ₁₆	2 ⁷ / ₈	3 ³ / ₁₆	1 ⁷ / ₈	
1 ¹ / ₂ x 1 ¹ / ₂ x 1 ¹ / ₄	1.900 x 1.900 x 1.660	0090-0454-082	3	2	2 ⁷ / ₈	3 ⁵ / ₁₆	1 ⁷ / ₈	
2 x 1 ¹ / ₄ x 2	2.375 x 1.660 x 2.375	0090-0458-082	4	2 ⁵ / ₁₆	3 ³ / ₈	4 ¹ / ₁₆	2 ¹ / ₄	
MALE ADAPTER - SEAL ONLY								
3/4 x 3/4 MIPS	1.050	0090-0740-082	2 ⁷ / ₃₂	4	3 ²⁷ / ₃₂	--	--	
1 x 1 MIPS	1.315	0090-0741-082	2 ⁹ / ₁₆	4 ¹ / ₄	3 ¹³ / ₁₆	--	--	
1 ¹ / ₄ x 1 ¹ / ₄ MIPS	1.660	0090-0757-082	3	4 ⁷ / ₁₆	3 ⁷ / ₈	--	--	
1 ¹ / ₂ x 1 ¹ / ₂ MIPS	1.900	0090-0743-082	3 ³ / ₈	4 ⁹ / ₁₆	3 ⁷ / ₈	--	--	
2 x 2 MIPS	2.375	0090-0744-082	4	4 ¹¹ / ₁₆	4	--	--	
LINE CAP - SEAL ONLY								
3/4	1.050	0090-0860-082	2 ⁷ / ₃₂	3 ¹ / ₈	2 ¹¹ / ₁₆	--	--	
1	1.315	0090-0861-082	2 ⁹ / ₁₆	3 ¹ / ₈	2 ¹¹ / ₁₆	--	--	
1 ¹ / ₄	1.660	0090-0862-082	3	3 ¹ / ₈	2 ¹¹ / ₁₆	--	--	
1 ¹ / ₂	1.900	0090-0863-082	3 ³ / ₈	3 ⁵ / ₃₂	2 ¹¹ / ₁₆	--	--	
2	2.375	0090-0864-082	4	3 ¹ / ₄	2 ¹¹ / ₁₆	--	--	

NOTE: STYLE 90 PRODUCTS shown in this brochure are for **SEAL ONLY CONNECTIONS on Steel Pipe**. For all IPS, Plastic Pipe and Restraining Coupling applications, please refer to the DRESSER Universal Style 90 product line.



⚠ WARNING

When pipe pullout could occur as a result of forces other than that caused by internal line pressure of 150 psi maximum, pipe joint **MUST** be anchored. Failure to anchor pipe joint could result in escaping line content and cause property damage, serious injury or death.

⚠ WARNING

You **MUST** mark and stab the pipe into the fitting to the proper stab depth. Failure to do so could result in escaping line content that could cause property damage, serious injury or death.

Piping Specialties Dresser, Inc.

41 Fisher Avenue, Bradford, PA 16701
 Phone: (814) 362-9200
 Fax: (814) 362-9333
 Email: dmdsales@dresser.com



www.dresser.com